



Kit Contents		
Description	Part No	Pcs
Shock absorber	BMS 1140/2140	2
Dust boot	10216-01	2
Spring	47040-06	2
Lock nut M14	24627-04	2
Lower spring seat	24635-03	2
Lock ring	24636-03	2
Spacer	24629-15	2
Rebound adjuster	24631-02	2
C-spanner	24639-01	1
C-spanner	24639-03	1
Öhlins sticker kit	10207-01	1
Öhlins emblem kit	10207-02	1
Öhlins Owner's Manual	07451-01	1

**👁 Note!**

Please note that this image is a general representation of the product and may differ slightly from your product.

**👁 Note!**

Please note that during storage and transportation, especially at high ambient temperature, some of the oil and grease used for assembling may leak and stain the packaging. This is in no way detrimental to the product, wipe off the excessive oil/grease with a cloth.

**👁 Note!**

Before installing this product, check the contents of the kit. If anything is missing, please contact an Öhlins dealer.

**⚠ Warning!**

Before installing this product, read the Öhlins Owner's Manual. The shock absorber is an important part of the vehicle and the vehicle stability.

## Shock absorber Kit for BMW M3 (E90, E92) - front

# **BMS M140S1**

## Mounting Instructions



# MOUNTING INSTRUCTIONS

## **⚠ Warning!**

We strongly recommend to have an Öhlins dealer install this product.

## **⚠ Warning!**

If working on a raised vehicle, ensure that it is securely supported to prevent it from tipping over.

## **👁 Note!**

When working on this product, see the Vehicle Service Manual for vehicle specific procedures and important data.

**1**

Raise the vehicle and put it on jack stands.

## **⚠ Warning!**

Ensure that it is securely supported.

**2**

Remove the front wheels.

**3**

Loosen the bolts for the lower strut attachments.

## **👉 Caution!**

Support the wheel hubs in an appropriate way on each side of the vehicle so that the brake hoses can not be damaged.

**4**

Loosen the upper attachments. Remove the original struts from the car.

**5**

Cut the dust boot 62 mm from the lower end with a pair of scissors according to fig 2.

**6**

Tighten the lower spring seat and the lock ring to 50 - 60 Nm.

Fit the dust boot, the spring, the original washer, the original top mount and the lock nut M14 to the strut according to fig Tighten the lock nut to 35 - 40 Nm.

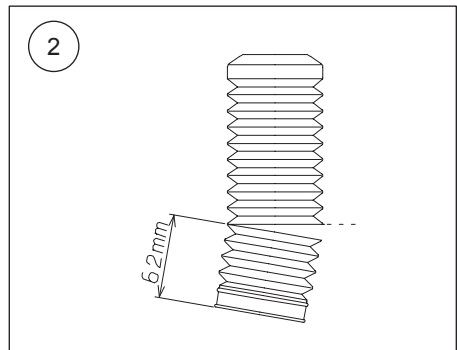
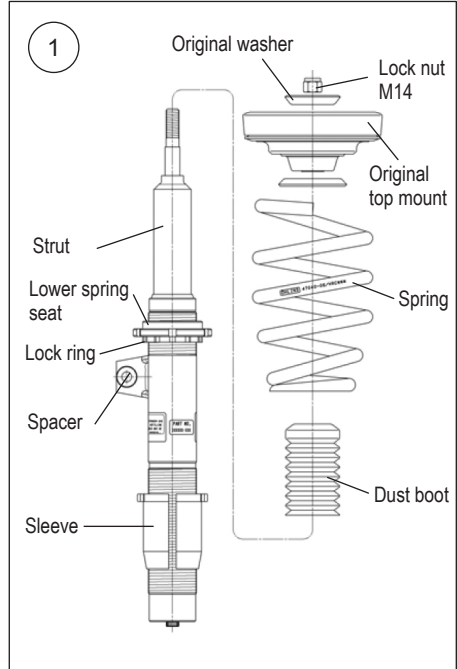

# MOUNTING INSTRUCTIONS

7

Install the Öhlins McPherson struts on the vehicle according to fig 4

Fit the stabilizer link according to fig 3.

8

Fasten the upper attachments.

**Note!**

*When tightening the top mount nut, the shock absorber shaft must be held in position with a 6 mm Allen key.*

9

Raise the wheel hub with a jack to remove the freeplay of the lower strut attachment bolts before tightening them.

**Note!**

*Make sure that all bolts are tightened to the correct torque and that nothing fouls or restricts movement of the strut when it is being fully compressed or extended. Test this over the whole steering range from lock to lock*

10

Make sure that all removed parts are reinstalled in the same way as they were before the installation of the Öhlins shock absorber.

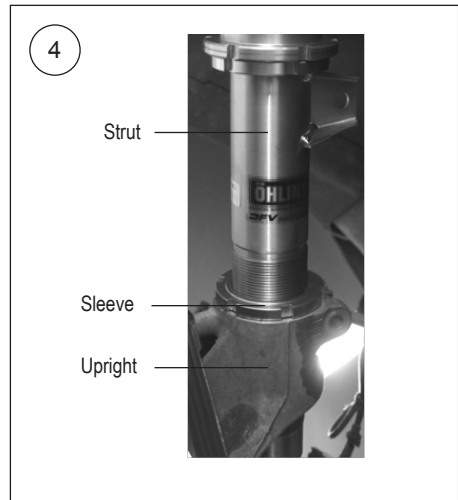
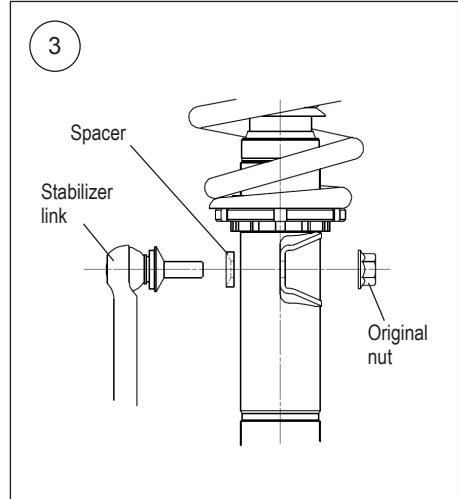

# ADJUSTMENTS

## **⚠ Warning!**

Before riding, always make sure that the basic settings made by Öhlins are according to recommended Set-up Data. Read about adjustments and setting up in the Öhlins Owner's Manual before you make any adjustments. Contact an Öhlins dealer if you have any questions about setting up.

The standard preload is 6 mm, see fig 6.

## SETUP DATA

### Recommended set-up

#### Rebound setting

Track	0-7	clicks
Winding road	5-10	clicks
Street	10-20	clicks

Spring preload	6	mm
Shock absorber length	529	mm

### Spring

47040-06 (60 N/mm)

### The actual vehicle height

With both the preload and height adjustments in their standard positions, the vehicle is lowered approximately 20 mm when compared to the original suspension. As the height adjuster is turned one rotation, the position moves 1.5 mm.

## **⚠ Warning!**

The adjustment range is the standard position  $\pm 15$  mm.

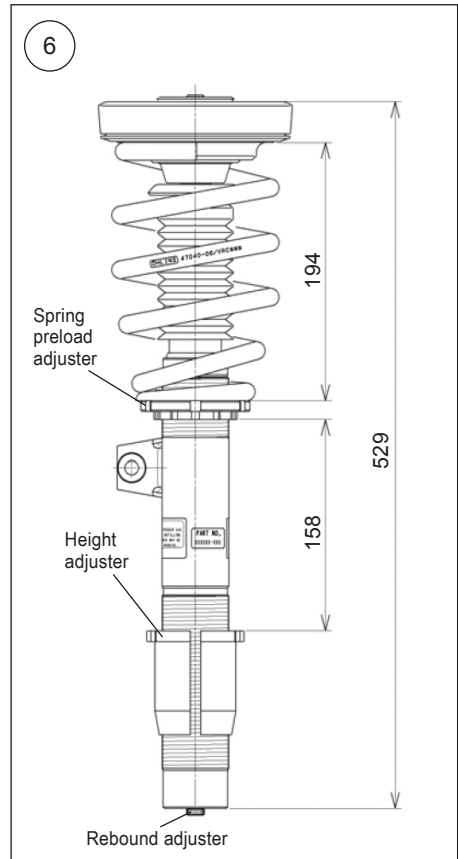

Öhlins products are subject to continuous improvement and development, therefore, although these instructions include the most up-to-date information available at the time of printing, minor updates may occur.

To find the latest information contact an Öhlins distributor. Please contact Öhlins if you have any questions regarding the contents in this document.

Part no. MI\_BMSMI40S1\_0 front  
Issued 2022-07-06

© Öhlins Racing AB. All rights reserved. Any reprinting or unauthorized use without the written permission of Öhlins Racing AB is prohibited.

Öhlins Racing AB  
Box 722  
S-194 27 Upplands Väsby, Sweden  
Phone +46 8 590 025 00  
fax +46 8 590 025 80



[www.ohlins.com](http://www.ohlins.com)



Kit Contents		
Description	Part No	Pcs
Shock absorber	BMS 6I40	2
Washer (EDC car)	24619-04	2
Spacer (for EDC)	24629-11	2
Rebound adjuster	24631-04	2
Lock nut M10	24626-01	2
Bushing spacer	24629-14	4
Dust boot	10216-01	2
Lock ring	24636-03	4
Spring	47020-39	2
Spring preload adjuster	24651-02	2
Rubber seat	25601-03	2
Lower plastic seat	25618-04	2
Spring seat	24635-03	2
Lock nut	24651-01	2
Adjuster	24631-04	

**Note!**

Please note that this image is a general representation of the product and may differ slightly from your product.

**Note!**

Please note that during storage and transportation, especially at high ambient temperature, some of the oil and grease used for assembling may leak and stain the packaging. This is in no way detrimental to the product, wipe off the excessive oil/grease with a cloth.

**Note!**

Before installing this product, check the contents of the kit. If anything is missing, please contact an Öhlins dealer.

**Warning!**

Before installing this product, read the Öhlins Owner's Manual. The shock absorber/front fork/steering damper is an important part of the vehicle and the vehicle stability.

## Shock absorber Kit for BMW M3 (E90, E92) - rear

# **BMS MI40S1**

### Mounting Instructions



# MOUNTING INSTRUCTIONS

## **⚠ Warning!**

We strongly recommend to have an Öhlins dealer install this product.

## **⚠ Warning!**

If working on a raised vehicle, ensure that it is securely supported to prevent it from tipping over.

## **👁 Note!**

When working on this product, see the Vehicle Service Manual for vehicle specific procedures and important data.

**1**

Raise the vehicle and put it on jack stands.

## **⚠ Warning!**

Ensure that it is securely supported.

**2**

Remove the rear wheels.

**3**

Remove the lower and the upper attachments and remove the original shock absorbers.

**4**

Remove the spring.

**5**

Set the spring seat of the spring preload adjuster to the position according to fig 6.

**6**

Remove the OEM upper spring cup according to figure 2.

**7**

Install the Öhlins spring and the spring preload adjuster on the vehicle according to fig 4.

**8**

Cut the dust boot 82 mm from the lower end with a pair of scissors according to fig 3.

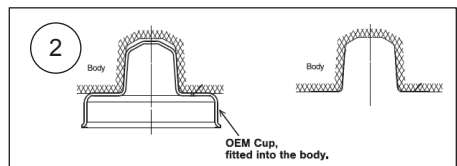
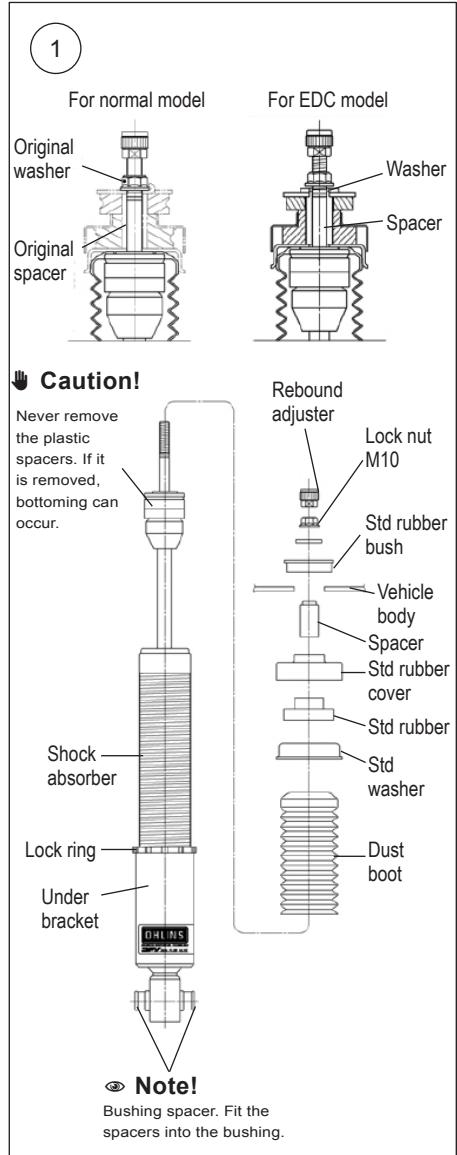

# MOUNTING INSTRUCTIONS

9

Tighten the lock ring to 50 - 60 Nm.

Fit the bushing spacers, the dust boot, the std rubbers, the spacer, the washers, the lock nut and the adjuster according to fig 1. Tighten the lock nut to 30 Nm.

The std nut must be removed from the std rubber bush according to fig

The spacer and the washer should be used for only EDC model.

## 👁 Note!

*When tightening the lock nut, the shock absorber shaft must be held in position with a 4 mm Allen key.*

10

Install the Öhlins shock absorbers on the vehicle.

11

Make sure that all removed parts are reinstalled in the same way as they were before the installation of the Öhlins shock absorber.

## 👁 Note!

*Make sure that all bolts are tightened to the correct torque and that nothing fouls or restricts movement of the shock absorber when it is being fully compressed or extended.*

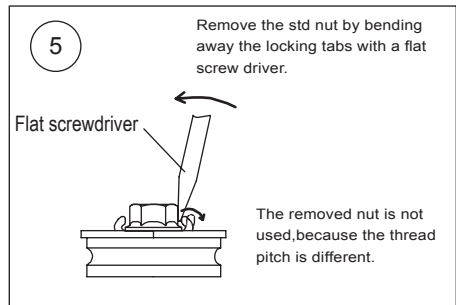
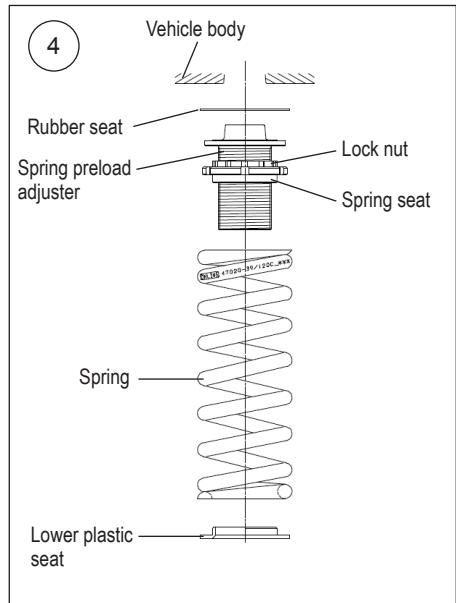
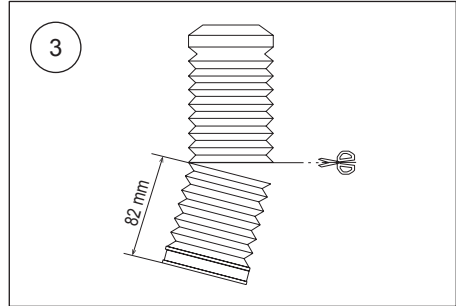

# ADJUSTMENTS

## **⚠ Warning!**

Before riding, always make sure that the basic settings made by Öhlins are according to recommended Set-up Data. Read about adjustments and setting up in the Öhlins Owner's Manual before you make any adjustments. Contact an Öhlins dealer if you have any questions about setting up.

# SETUP DATA

## Recommended set-up

### Rebound setting

Track	0-7	clicks
Winding road	5-10	clicks
Street	10-20	clicks

Spring preload adjuster height	37	mm
Shock absorber length	523	mm

## Spring

47020-39 (120 N/mm)

## The actual vehicle height

With both the preload and height adjustments in their standard positions, the vehicle is lowered approximately 20 mm when compared to the original suspension. As the height adjuster is turned one rotation, the position moves 1.5 mm.

## **⚠ Warning!**

The adjustment range is the standard position  $\pm 15$  mm. If the bracket is moved outside the adjustment range, it may come loose.

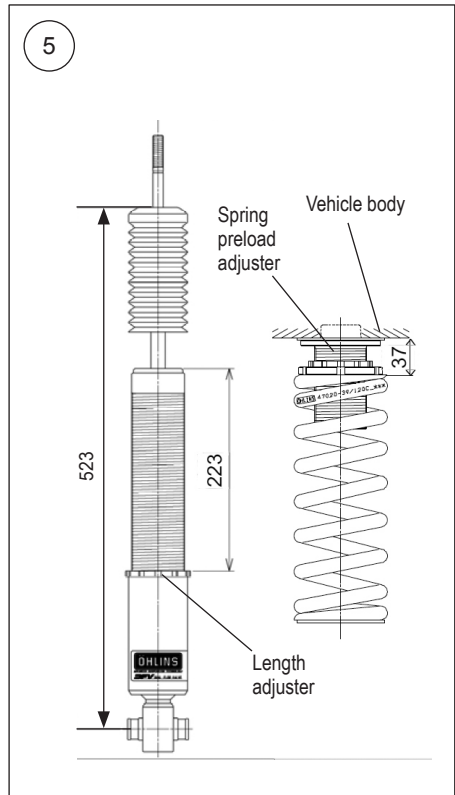

Öhlins products are subject to continuous improvement and development, therefore, although these instructions include the most up-to-date information available at the time of printing, minor updates may occur.

To find the latest information contact an Öhlins distributor. Please contact Öhlins if you have any questions regarding the contents in this document.

Part no. MI\_BMSM140S1\_0 rear  
Issued 2022-07-06

© Öhlins Racing AB. All rights reserved. Any reprinting or unauthorized use without the written permission of Öhlins Racing AB is prohibited.

Öhlins Racing AB  
Box 722  
S-194 27 Upplands Väsby, Sweden  
Phone +46 8 590 025 00  
fax +46 8 590 025 80



[www.ohlins.com](http://www.ohlins.com)