

# CAE Ultra Shifter

## Installation instructions

📍 10053

Ford Focus MK2 RS/ST  
6-Speed M66 transmission



# PLEASE NOTE

## SAFETY FIRST!

- ⚠ Please only do the installation if you have appropriate experience in the automotive sector and have the right tools! An incorrectly installed Shifter can seriously damage the transmission or make the vehicle undriveable or not shiftable and lead to serious accidents!
- ⚠ If work on the electrical system is necessary, please follow the manufacturer's specifications.
- ⚠ It is essential to leave the ignition switched off when the plugs are disconnected.  
Do not leave the car key in the vehicle.
- ⚠ Carry out all work with care and cleanliness! For the professional assembly of a shifter is no force required. All parts are designed to fit your vehicle.
- ⚠ If you are unsure, please contact your trusted workshop about the installation!

## BASICALLY

- ⚠ Use ethyl alcohol/brake cleaner to clean all aluminum parts.
- ⚠ Occasionally lubricate all moving parts with spray grease, which has good creeping properties.  
Our recommendation: Würth HHS 2000 (WD-40 or similar is unsuitable because it is too thin)
- ⚠ All screws and nuts that are not self-locking or are fitted with tooth lock washers glue in during assembly!
- ⚠ Never kink shift cables, please!

### **i SURFACES AND THEIR CARE**

Please note that an untreated aluminum surface (ALU) is sensitive to aggressive Liquids to which i.a. Hand sweat also counts. Especially the high-strength 7075 aluminum we use has a tendency to form black spots of corrosion due to its high copper content. Under special circumstances, very salty air near the sea and coast can lead to corrosion. The surfaces should therefore be cleaned regularly and treated with care to prevent this. For this purpose, e.g. ethyl alcohol or brake cleaner. Only spray these onto a cloth and wipe the shifter with it, NEVER spray the shifter directly. If stains have already formed, they can be removed with commercially available aluminum polish, but that is also not allowed get into the movable parts of the shifter. The anodized versions of our shifters (EXS, EXGR) are more resistant to corrosion. The steel parts have to be also cared in all variants.

## TIPS FOR GEAR SHIFTING

### **i FORCE DOESN'T MAKES YOU FASTER - IT ONLY HARMS THE TRANSMISSION**

The question arises again and again: "Does a CAE shifter puts more strain on a gearbox than a standard gear lever?" The answer is clear: "No!" The things that are most stressful for a synchronizer ring in a transmission are excessive shifting forces or a wrong shift in gear. Basically, the shift travel with a CAE Shifter is significantly shorter than with the standard lever. We achieve 30 - 55 % reduction depending on the vehicle and transmission type. This can only be achieved by using the appropriate gear ratio on the shift lever. You can feel it through the precision of a CAE shifter engaging the gears is much better than with a standard gear lever designed for comfort. The force for this decreases in the same proportion - we put in the gears with significantly less load for the synchronizer rings. In addition, with a correctly adjusted CAE shifter put in the gears is very precise and shifting into the wrong gear is extremely rare. Even in motorsport, fast, precise, but still sensitive shifting leads to the goal! Everything else is pure tugging and tearing (often seen on various YT channels), which looks "important", but in no way makes it faster - but it puts a disproportionately high strain on a transmission and in the worst case causes a fatal wrong shift in gear!

**i** The shifter is designed for vehicles with interior. The center console remains in its original condition and does not need to be machined. The shift bag is omitted.

**i PLEASE NOTE:** No lifting platform is necessary for the installation of this shifter. All work is to be carried out in the interior.

### Disassembling

- ▶ Pull up shift bag (Picture 1), loosen upper cover of center console (one screw in cup holder / plug from start button). Remove the handbrake bag with cover. There are two screws under the armrest. Loosen center console via the two hexagonal screws at the front and rear (Picture 2-4). Disconnect the connector at the front left and remove the center console.
- ▶ Unbutton the shift cables and detach them from the gearshift bracket (Picture 5). To do this, push the sliding sleeves on the shift cables (in front of the gearshift bracket) forward and lift the cables.
- ▶ Disconnect the reverse gear lock switch from the series bracket (turn the metal plate forwards / Picture 6) and unthread it to the left. It is best not to disconnect the plug at all.
- ▶ Remove original shift lever completely (4 screws / Picture 5).

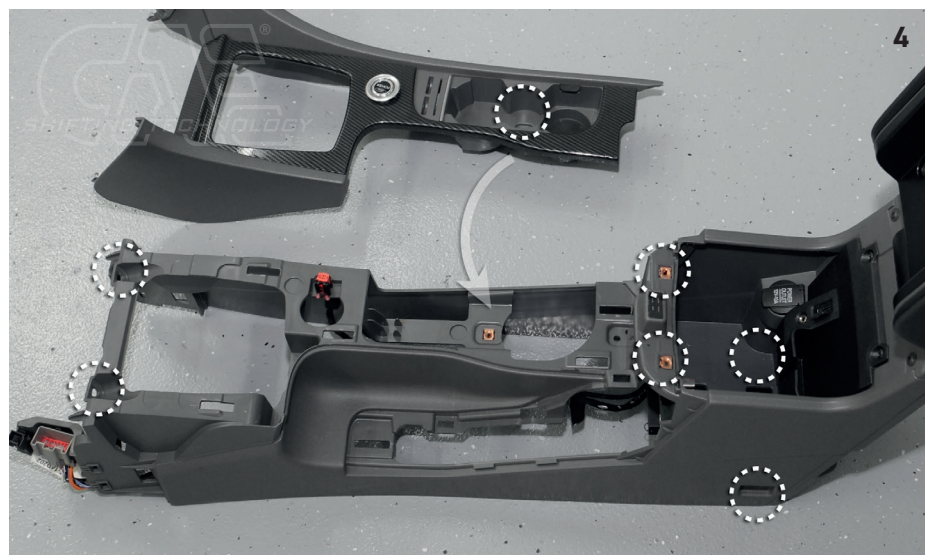
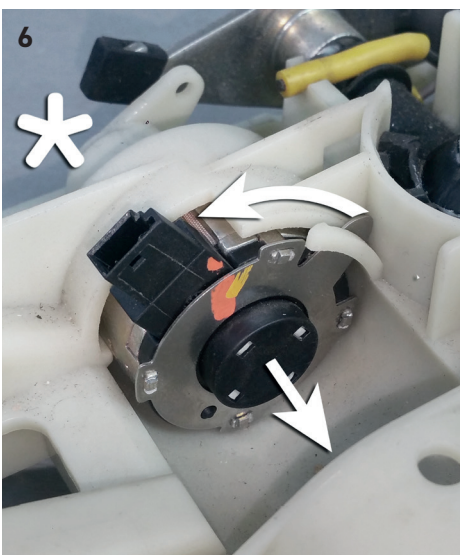
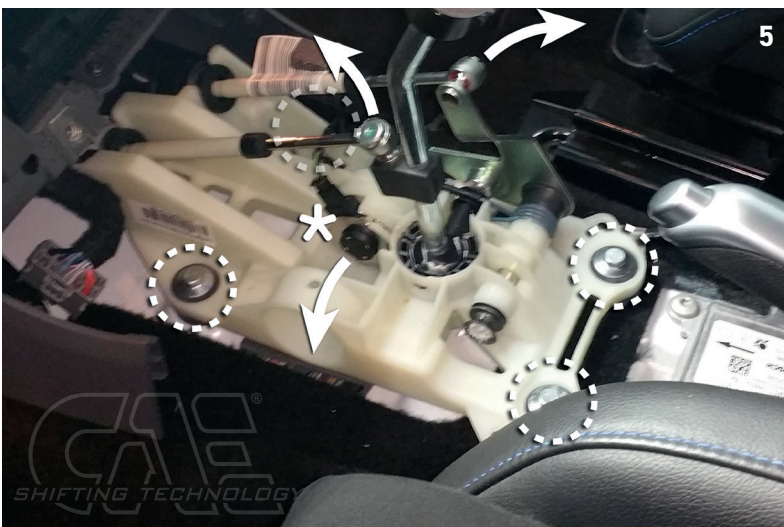

## The installation

- ▶ Disassemble the CAE shifter by loosening the 4 connecting screws and pulling off the coupling rods at the upper joint.
- ▶ Place the supplied spacers on the center tunnel and align over the threaded holes.
- ▶ Place the CAE shifter on the center tunnel and align it over the threads (Picture 6), inserting the shift cables into the shifter. Tighten the Shifter lower part with the screws and spring washers supplied.
- ▶ Push in the shift cables on the front plate from above until the sliding sleeves engage. Then press the ball cups onto the lower balls of the L-levers.

**ⓘ PLEASE NOTE:** Hold the left lever against the housing, otherwise the housing will be deformed and the lever will then rub against the lower edge of the housing!

- ▶ Insert reverse gear lock switch into the eyelet on the front panel and secure with the grub screw (Picture 7).

**ⓘ PLEASE NOTE:** The locking switch now has no function! The assembly serves only the electronic error prevention, otherwise the parking aid does not work. The plug must be plugged in before the ignition is switched on!

- ▶ Replace shifter upper part and screw on (the upper part is removed again for installation of the center console).
- ▶ Press on the short coupling rod to the lower part of the shift lever.

## Adjustment of gear shift paths

### 6-speed transmission

- ▶ Adjust the center position of the shift lever: Loosen the spring stop (Picture 8) under the shift tower and align the shift lever. It should now be exactly straight. Tighten the spring stop again. Only loosen this screw with an Allen key (SW 5 mm / approx. 2 turns), but never unscrew it completely!
- ▶ Shift the transmission to 3rd gear. To do this, move the shift lever forward without moving it sideways.
- ▶ Adjust the right (long) coupling rod to the L lever by turning it so that the ball socket can be pressed on without changing its length.

**ⓘ PLEASE NOTE:** The cup with ring groove on the neck has a left-hand thread!

**!** **TEST:** With 3rd and 4th gear engaged, the lateral play at the shift lever must be equal, otherwise readjust at the coupling rod!

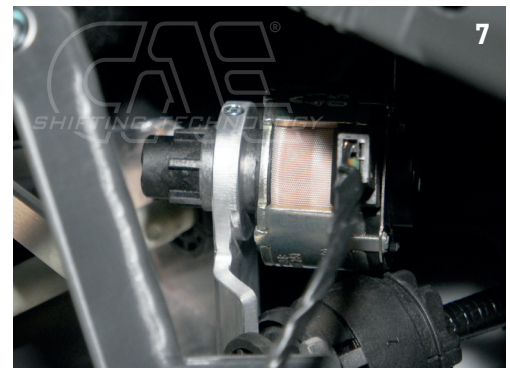
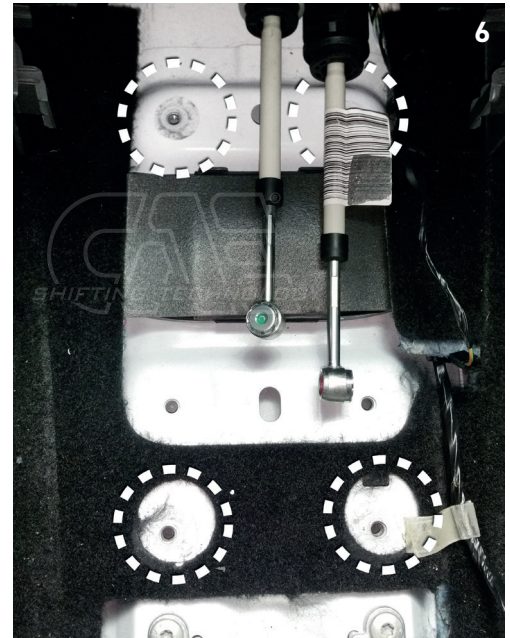

- ▶ Secure all ball cups of the coupling rods with the lock nuts.
- ▶ Shift the transmission to level 1/2 using the shift lever and screw in the stop screw until the gears can be changed cleanly.
- ▶ Now shift the transmission to gear level 5/6 using the shift lever and screw in the stop screw, likewise until the gears can be engaged cleanly.
- ▶ Proceed in exactly the same way with the reverse gear and the associated adjusting screw. Check the settings later during a test drive and readjust if necessary.

**ⓘ PLEASE NOTE:** The stop screws (Picture 10) must never touch the bolt when the gear is engaged. A distance of approx. 0.5 mm is okay.

### Reassembly of the center console

- ▶ The lower cotter pin clips of the coupling rod are factory mounted and do not need to be removed, the upper ones are mounted after the center console is installed.
- ▶ After everything is adjusted, pull off the ball heads of the two coupling rods at the top again and unscrew the shifter upper part to install the center console (Picture 11).
- ▶ Place the upper part of the shifter and use needle-nose pliers or tweezers (Picture 12) to position the fastening screws, then tighten them with an 8 mm open-end wrench.
- ▶ Press the coupling rods back on and secure them with the cotter pin clips provided.

**!** **FINALLY** check all functions and settings during the test drive and readjust if necessary!  
**Incorrect or inaccurate settings can cause damage to the gear box and consequential damage!**

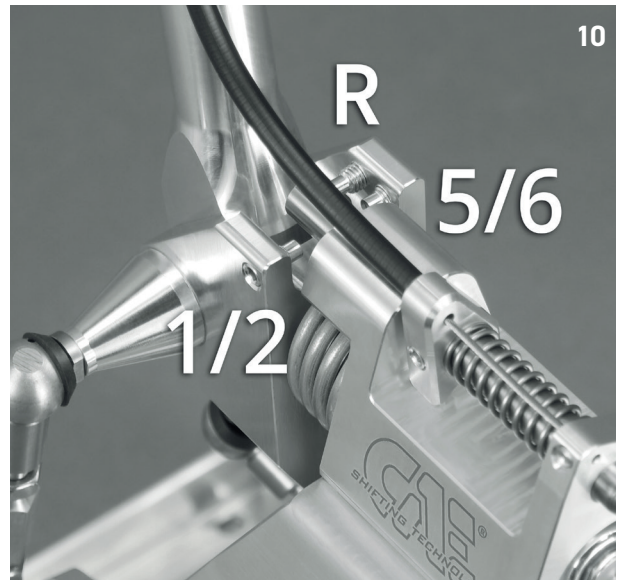

# RACE THE ORIGINAL



Alte Bottroper Strasse 103  
D-45356 Essen  
0049. 201. 8 777 802  
service@cae-racing.de

[WWW.CAE-RACING.DE](http://WWW.CAE-RACING.DE)