

PLUMBING MUST BE FLEXIBLE LINES AT INLET AND OUTLET OF PIVOT TYPE MASTER CYLINDERS. MASTER CYLINDERS MUST BE ALLOWED TO MOVE SLIGHTLY DURING ADJUSTMENT AND USE.

TORQUE PUSHROD JAM NUTS TO 144 LB-IN DO NOT USE THREAD LOCKING COMPOUND, 3 PL.

CLEVIS DESIGNED FOR MINIMUM FREE PLAY WITH OR WITHOUT JAM NUTS

LOW FRICTION DRY LUBE AND HARD COATING ON CLEVISES

SET TO 2.62 ± 0.05 [66.7 ±1.3]

ADJUST PUSHROD TO CLEVIS ENGAGEMENT SO THAT BALANCE BAR IS PARALLEL TO FIREWALL WHILE UNDER NORMAL BRAKING LOAD, THEN TIGHTEN JAM NUTS TO 144 IN-LB. DO NOT USE THREAD LOCKING COMPOUND.

JAM NUT SECURES BIAS BAR SETTING.

FOR REMOTE CABLE ADJUSTER, REMOVE JAM NUT AND SECURE CABLE TO END OF BIAS BAR WITH CABLE COUPLER

FOR CLUTCH, DO NOT EXCEED 3 DEGREES OF PUSHROD ANGULARITY DURING STROKE OF PEDALS. PREMATURE MASTER CYLINDER WEAR MAY OCCUR.

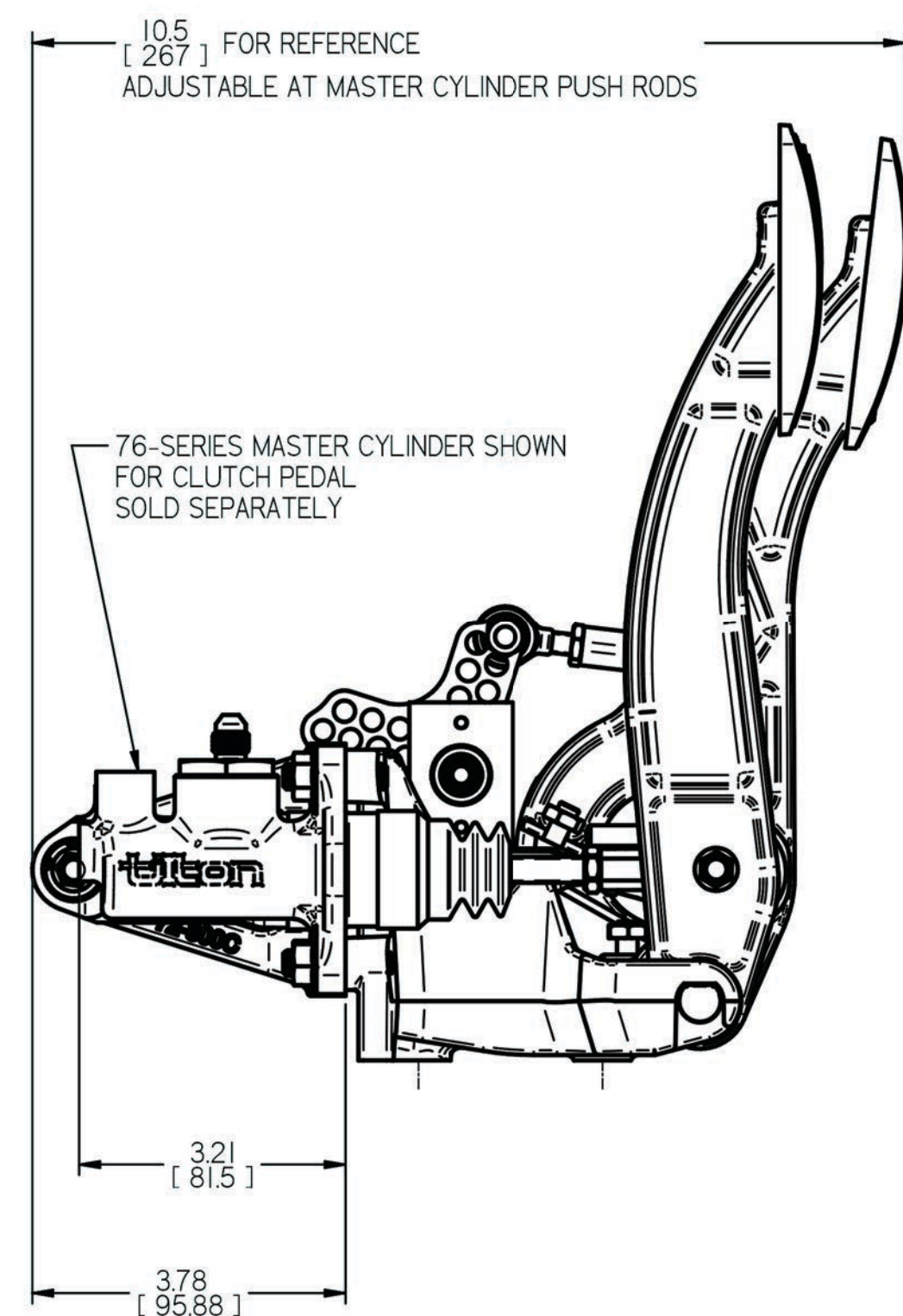

ALL PEDALS:
 .75 (19.1mm) TOTAL HEIGHT ADJ., 4 POS.
 .58 (14.7mm) TOTAL HORIZONTAL ADJ., 3 POS.

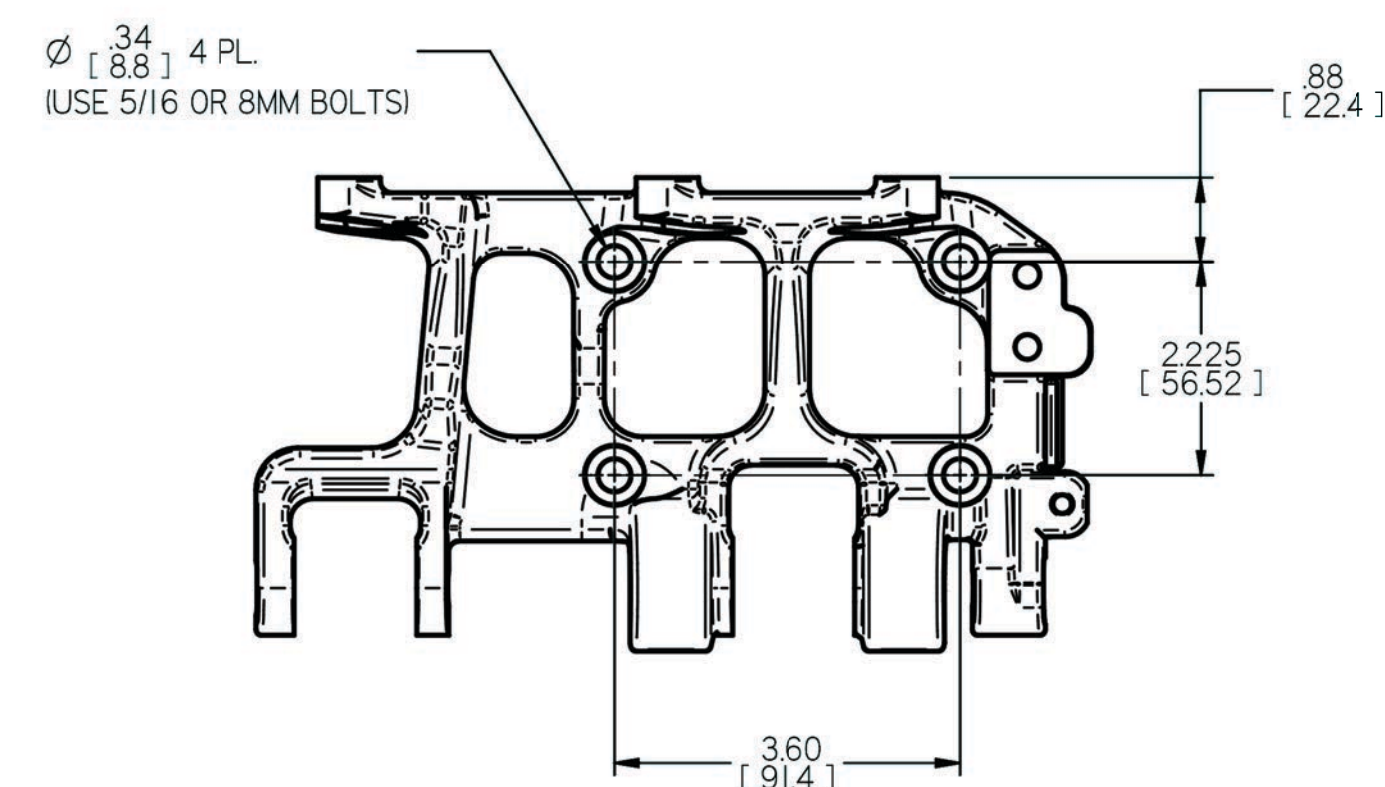
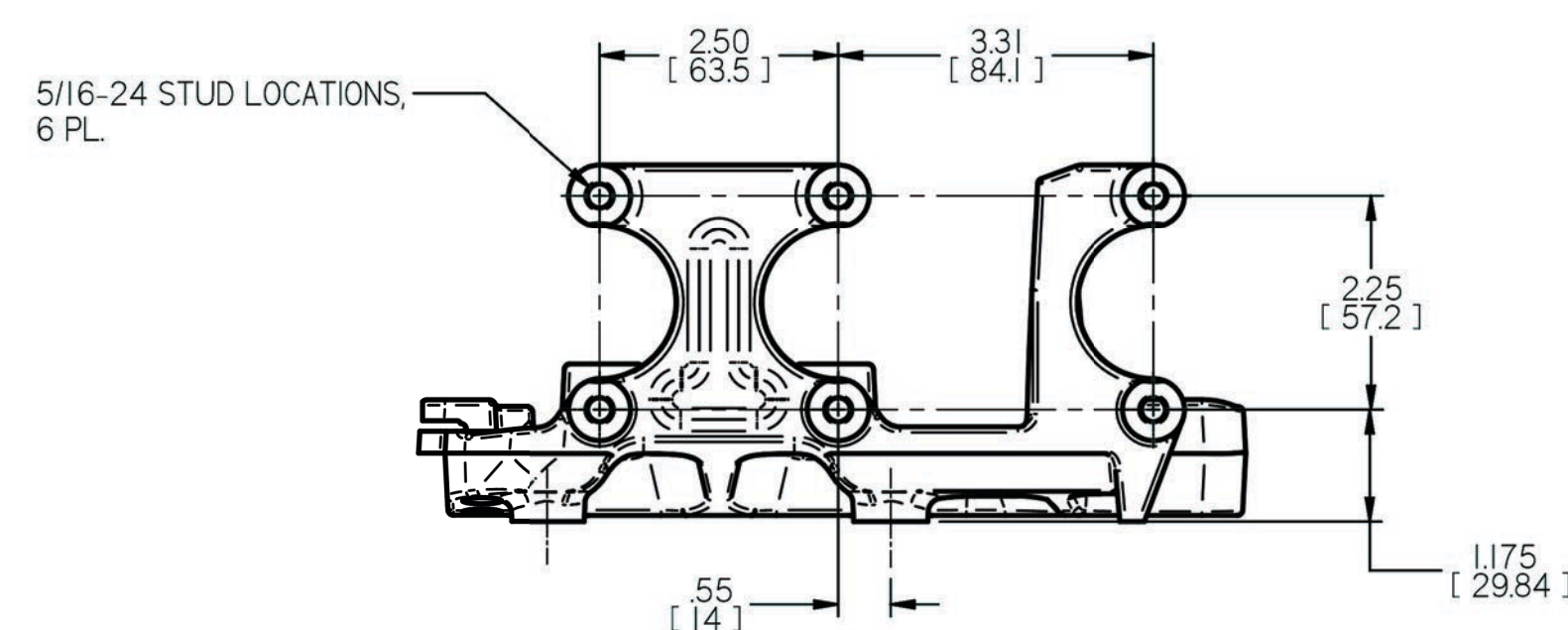
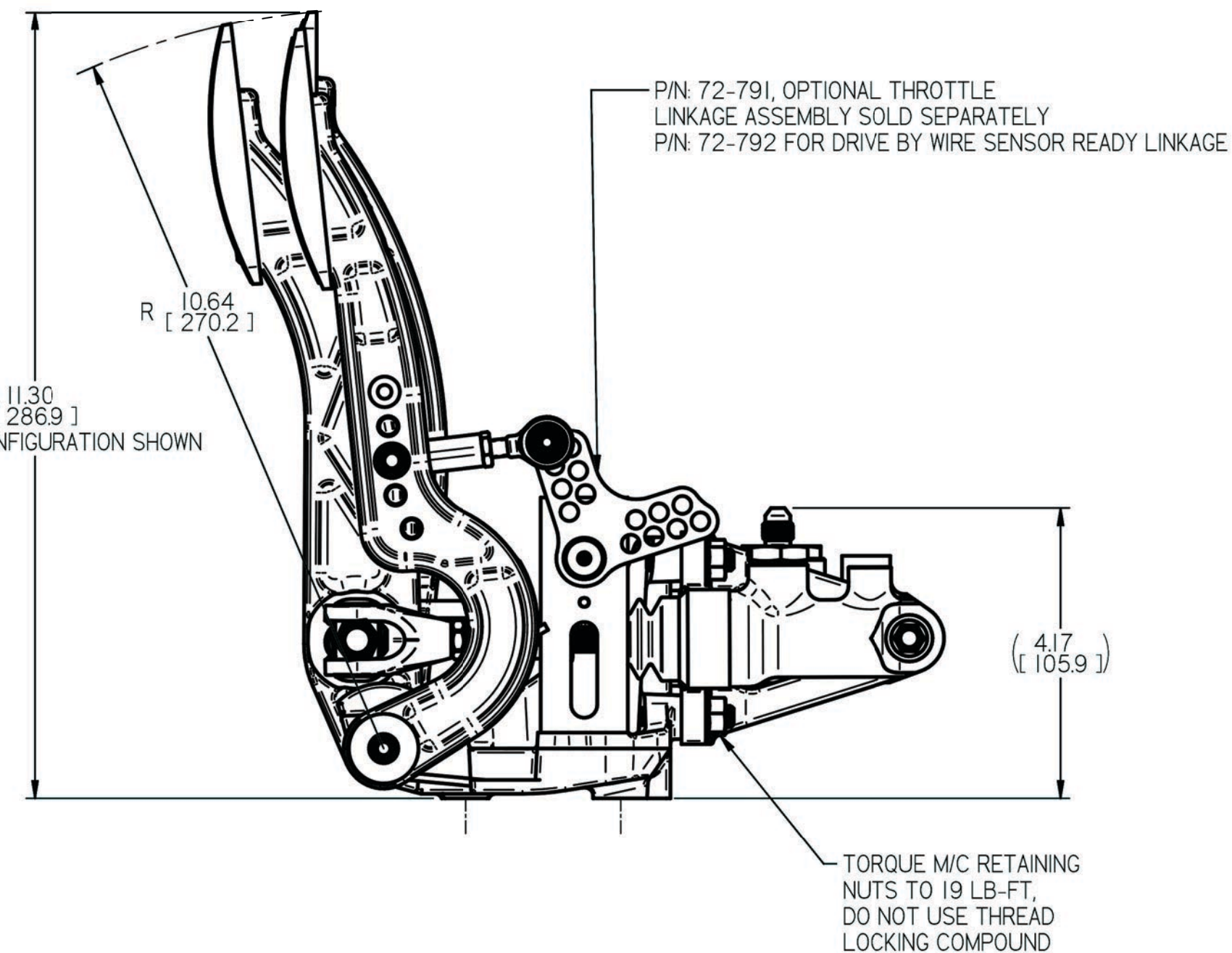
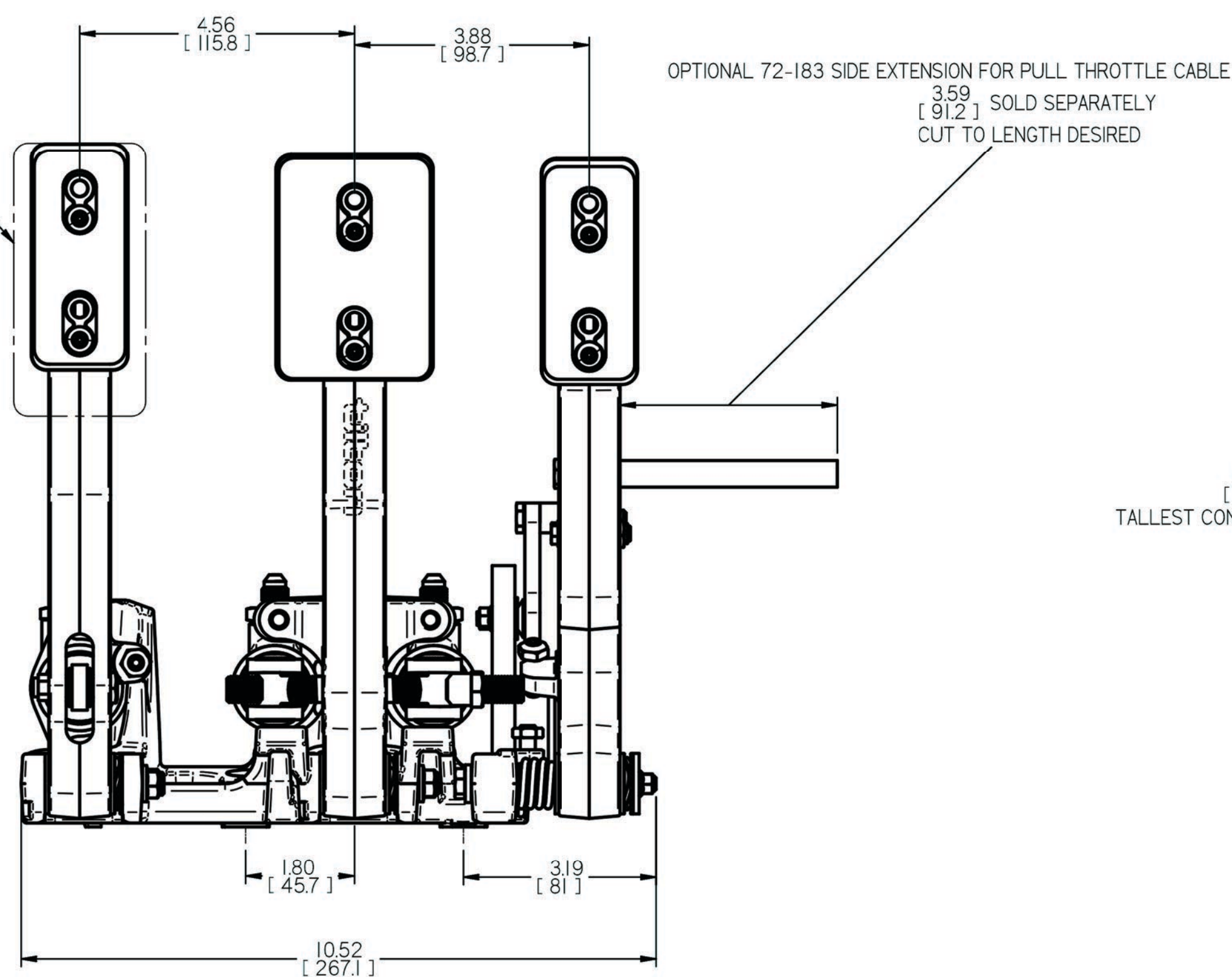

PEDAL ASSEMBLY IS COMPATIBLE WITH TILTON ENGINEERING 73, 74, 75 OR 76 SERIES MASTER CYLINDERS AT THE CLUTCH PEDAL LOCATION AND ARE SOLD SEPARATELY

77, 78 SERIES MASTER CYLINDERS ARE TO BE USED AT THE BRAKE PEDAL LOCATION AND ARE SOLD SEPARATELY

76/78 SERIES MASTER CYLINDERS SHOWN HERE ARE FOR ILLUSTRATION PURPOSES ONLY AND ARE NOT INCLUDED WITH PEDAL ASSEMBLY

NOTES:

1. DIMENSIONS AND TOLERANCES PER ASME Y14.5 - 2009
2. UNLESS OTHERWISE SPECIFIED, ALL DIMENSIONS ARE IN INCHES [MM].
3. DIMENSIONS ARE NOMINAL.

TILTON ENGINEERING, INC.		(805) 688-2353 FAX (805) 688-2745	
25 EASY STREET P.O. BOX 1787 BUELLTON, CALIFORNIA 93427 USA			
TITLE: PEDAL ASSEMBLY, FLOOR MOUNT, PIVOT TYPE MASTERS INSTALLATION DRAWING, 3 PEDAL, ALUMINUM			
DRN BY LUND	CHKD WAHL	SCALE 1:2	DWG 6349
P/N 72-803	DATE 9/7/2016	SHEET 1 OF 1	REV NC

This document contains proprietary information of TILTON ENGINEERING, INC., and its receipt or possession does not convey the rights to reproduce, disclose its contents, or to manufacture, use or sell anything it may describe. Reproduction, disclosure, or use without specific written authorization of TILTON ENGINEERING, INC. is strictly forbidden.

TILTON ENGINEERING